

# WINDOW LIFT MOTOR AND REGULATOR REPLACEMENT PROCEDURE

1989-1994 NISSAN MAXIMA FRONT & REAR

## DOOR TRIM REMOVAL

The following applies to both front and rear doors. Use a No. 3 Phillips screw driver. Remove ash tray and remove screw now exposed. Carefully remove plastic cover plate at the bottom of the pull door handle housing and remove screw. Remove plastic plug on handle grip and remove screw and handle and also remove newly exposed screw. Carefully remove trim and disconnect wiring to switches and lights.

## MOTOR AND REGULATOR REMOVAL

***Important - Before removing glass attaching bolts or channel rollers, secure glass with tape or a suitable wedge like a window wedge tool. When the glass is separated from the regulator move the glass to the closed position and retain in a similar manner.*** Check for bad connections, fuses or switches and the possibility of broken regulator or broken cable. Check to make sure the glass channels are clean and free from obstructions. All regulator mounting attaching hardware requires a 10mm socket or wrench. The regulator needs to be in position to remove glass mounting bolts (see drawings on opposite side). If the motor has stopped where the glass attaching bolts are not accessible, cut one of the regulator drive cables with a suitable tool. This will allow movement of the glass so glass mounting bolts are accessible. Remove glass attaching bolts. Be sure glass stays in the channels. Mark on the door the original position of the top two regulator mounting bolts before removing. Remove all 7 regulator mounting bolts. Remove regulator and motor assembly by sliding through large access hole in the door panel.

## MOTOR AND REGULATOR INSTALLATION

Insert new motor and regulator into the door while making sure the glass is still in the closed position. Loosely fasten regulator to door beginning with mounting holes by the motor and then loosely fasten the regulator bolts. The glass mounting holes on the replacement motor and regulator should be in position for access through the door. Slide down glass and fasten to regulator. Align top two regulator mounting bolts with marks indicating original position. Tighten down all bolts. Attach window lift wiring to switch on unattached trim and test operation. Reconnect remaining wiring and affix trim to door.

**88200 / WLA1437 & 88201 / WLA1438 MAXIMA FRONT MOTOR & REGULATOR**

View - 88200 / WLA1437 Left Front Facing Door from Outside Car

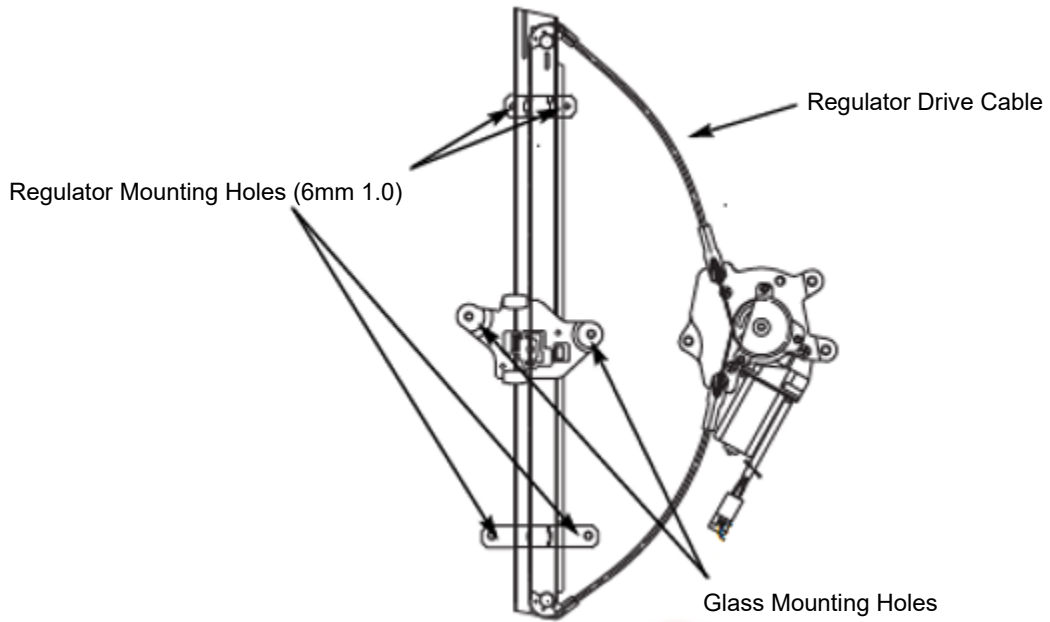

**88202 / WLA1439 & 88203 / WLA1512 MAXIMA REAR MOTOR & REGULATOR**

View - 88202 / WLA1439 Left Rear Facing Door from Outside Car

