

# WINDOW LIFT MOTOR AND REGULATOR REPLACEMENT PROCEDURE

1988-1992 TOYOTA COROLLA FRONT & REAR

## DOOR TRIM REMOVAL

Remove any screws attaching the trim. On some models remove door handle cover plate and trim plugs that cover screws. It is recommended to use a no. 2 phillips screw driver. Check for any hidden screws that were missed. Carefully pry panel from door (use proper trim removal tool if available) and disconnect wiring from switches and lights.

## MOTOR AND REGULATOR REMOVAL

**Important - Before removing glass attaching bolts or channel rollers, secure glass with tape or a suitable wedge like a window wedge tool. When the glass is separated from the regulator move the glass to the closed position and retain in a similar manner.** Check for bad connections, fuses or switches and the possibility of broken regulator or broken assist spring. Check to make sure the glass channels are clean and free from obstructions. **Front** - the regulator needs to be in position to remove glass mounting bolts (see drawings on opposite side). If window needs to be raised or lowered for access, start by removing the six regulator mounting bolts (requires a 10mm socket or wrench) so the regulator and glass can be moved together slowly into an accessible position. Remove glass mounting bolts. Slide regulator and motor through hole in the door panel. **Rear** - Remove regulator mounting bolts and slide channel roller out of glass channel. Slide regulator and motor through hole in the door panel. Be sure glass stays in the channels. Remove regulator and motor assembly by sliding through large access hole in the door panel. Be sure glass stays in the channels

## MOTOR AND REGULATOR INSTALLATION

**Front** – Insert new motor and regulator into the door while making sure the glass is still in the closed position. Loosely fasten regulator to door beginning with mounting holes by the motor and then loosely fasten the door channel. The glass mounting holes on the replacement motor and regulator should be in position for access through the door. If the mounting holes are not accessible, the regulator must be removed from the mounting locations and put in position to meet the glass for accessible mounting. Fasten glass to regulator and then move regulator and glass so regulator can be mounted. **Rear** - Insert regulator through access hole and insert roller into glass channel. Carefully lower glass and regulator together until regulator mounting holes are lined up with bolt holes in the door and fasten regulator into place. Tighten all the bolts. Attach window lift wiring to switch on unattached trim and test operation. Reconnect remaining wiring and affix trim to door.

**88304 / WLA1446 & 88305 / WLA1529 COROLLA FRONT MOTOR & REGULATOR**

View - 88304 / WLA1446 Left Front Facing Door from Inside Car

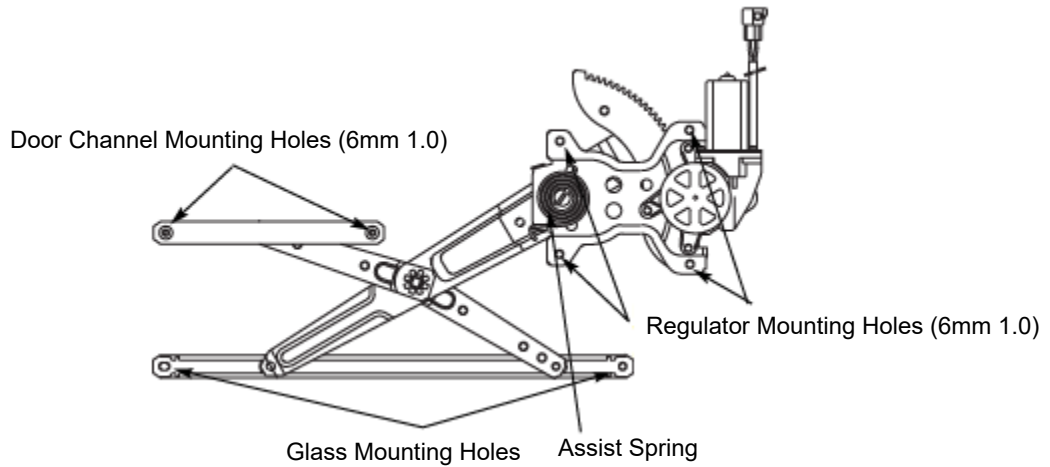

**88306 / WLA1530 & 88307/ WLA1531 COROLLA REAR MOTOR & REGULATOR**

View - 88306 / WLA1530 Left Rear Facing Door from Inside Car

