

WINDOW LIFT MOTOR AND REGULATOR REPLACEMENT PROCEDURE

1992-1996 TOYOTA CAMRY FRONT & REAR

Before removing regulator and motor, check fuses, switches and connections.

DOOR TRIM REMOVAL

Use a No. 3 Phillips screw driver. Front - Remove plugs from door pull handle. Remove screw covers near the hinge side of door. Remove screws from both locations. Remove plastic cover in map pocket and remove exposed screw. Remove two plastic pins located on the latch side of door. Carefully pry panel from door (use proper trim removal tool if available) and disconnect wiring from switches and lights. Rear - Remove plugs from door pull handle. Remove plastic pins on the hinge and latch side. Carefully remove trim. Carefully pry panel from door (use proper trim removal tool if available) and disconnect wiring from switches and lights.

MOTOR AND REGULATOR REMOVAL

Important - Before removing glass attaching bolts or channel rollers, secure glass with tape or a suitable wedge like a window wedge tool. When the glass is separated from the regulator move the glass to the closed position and retain in a similar manner.

Check to make sure the glass channels are clean and free from obstructions. All regulator mounting attaching hardware requires a 10mm socket or wrench. The regulator needs to be in position to remove glass mounting bolts (see drawings on opposite side). If the motor has stopped where the glass attaching bolts are not accessible, cut one of the regulator drive cables with a suitable tool. This will allow movement of the glass so glass mounting bolts are accessible. Secure glass and remove glass mounting bolts then the regulator and motor mounting nuts. Slide motor and regulator through opening in door.

MOTOR AND REGULATOR INSTALLATION

Insert new motor and regulator into the door while making sure the glass is still in the closed position. Loosely fasten regulator to door beginning with mounting holes by the motor and then loosely fasten the regulator nuts. The glass mounting holes on the replacement motor and regulator should be in position for access through the door. Slide down glass and fasten to regulator. Tighten down all nuts. Attach window lift wiring to switch on unattached trim and test operation. Reconnect remaining wiring and affix trim to door.

88308 / WLA7004 & 88309 / WLA7016 CAMRY FRONT MOTOR & REGULATOR

View - 88308 / WLA7004 Left Front Facing Door from Outside Car

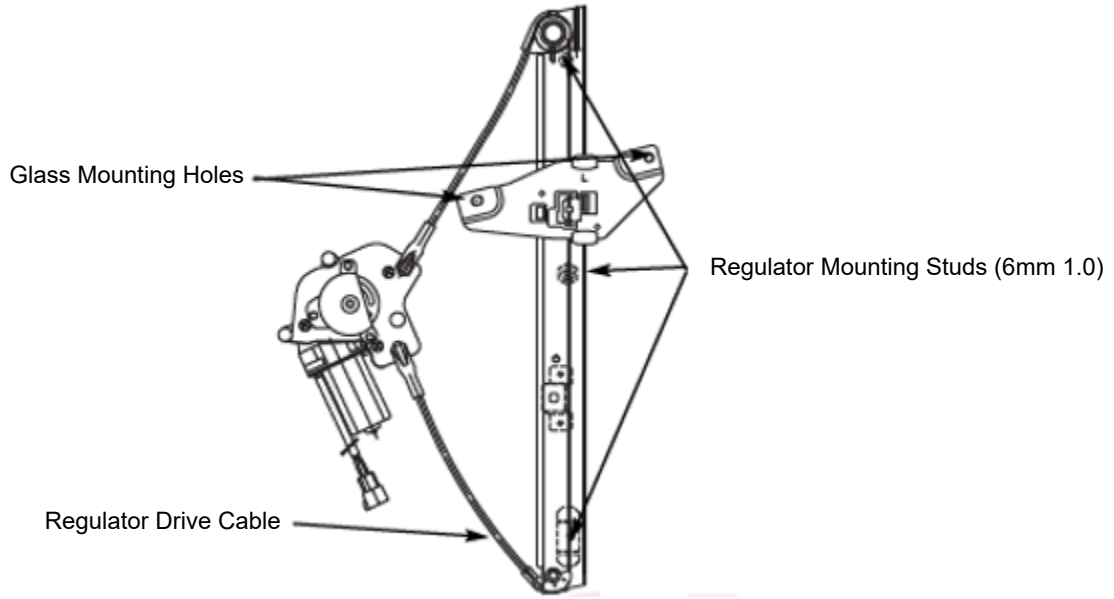

88310 / WLA1163 & 88311 / WLA1285 CAMRY REAR MOTOR & REGULATOR

View - 88310 / WLA1163 Left Rear Facing Door from Outside Car

